

OPTIONAL TERMINALS FOR PUSH ON CONNECTIONS (.032 X .250) [0.8 X 6.4] SUPPLIED

STANDOFFS TAPPED 1/2-13 X .50 (12.7) DEEP FOR MTG. BOLTS (4) PLACES

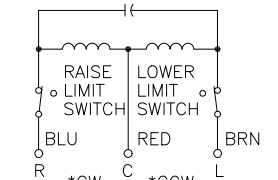
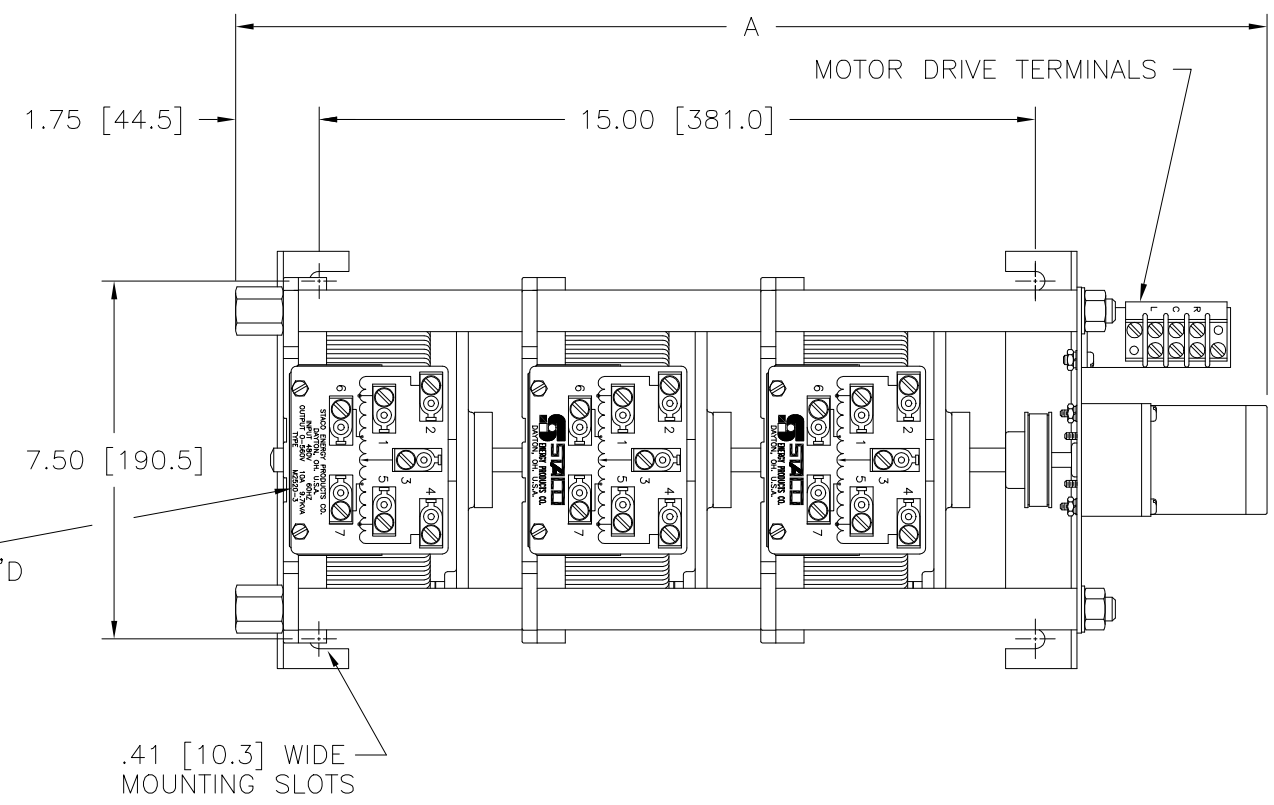

MOTOR CIRCUIT
 120V, 50/60 HZ
 * ROTATION AS VIEWED FROM MOTOR END
 MOTOR SPEED: SEE CHART

SPEED (SECONDS)	MODEL NUMBER	DIM "A"
5	5M2520-3	21.23 [539.2]
15	15M2520-3	21.23 [539.2]
30	30M2520-3	21.62 [549.1]
60	60M2520-3	21.62 [549.1]

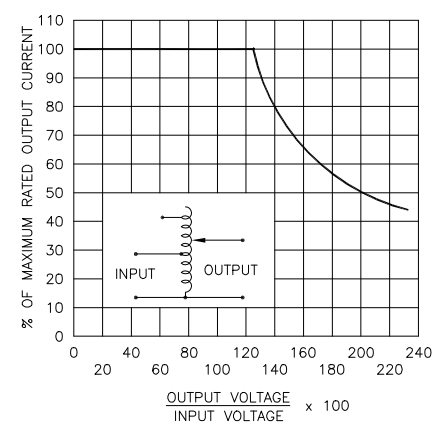

FIGURE A
 MAXIMUM OUTPUT CURRENT OF ANY DUAL INPUT VOLTAGE OR VOLTAGE DOUBLER UNIT OPERATED AT LOWER INPUT VOLTAGE.

MAXIMUM OUTPUT CURRENT IN OUTPUT VOLTAGE RANGE FROM 0 TO 25% ABOVE LINE VOLTAGE. AT HIGHER OUTPUT VOLTAGES, THE OUTPUT CURRENT MUST BE REDUCED ACCORDING TO THE DERATING CURVE FIGURE A.

§ MAXIMUM KVA AT MAXIMUM OUTPUT VOLTAGE AND CORRESPONDING DERATED OUTPUT CURRENT. MAXIMUM KVA FOR LOWER VOLTAGES MAY BE CALCULATED FROM DERATING CURVE FIGURE A.

++ LINE TO LINE VOLTAGE.

** REQUIRES THREE 52LAC PARALLELING CHOKE (NOT SUPPLIED).

∇ IF GANGED UNITS ARE USED IN A SYSTEM THAT ORDINARILY HAS A COMMON NEUTRAL OR GROUND BETWEEN SOURCE AND LOAD, THE NEUTRAL OR GROUND MUST BE CONNECTED TO THE COMMON TERMINALS OF THE VARIABLE TRANSFORMER ASSEMBLY. IF THE SYSTEM HAS NO NEUTRAL, THE LOAD MUST BE BALANCED OR THE TRANSFORMER WILL BE DAMAGED.

■ JUMPER PROVIDED IN STANDARD COMMON POSITION AND SHOULD BE MOVED OR REMOVED AS REQUIRED.

+ MOTOR DRIVEN UNITS USE TERMINAL CONNECTIONS FOR CCW INCREASING VOLTAGE, AS VIEWED FROM THE BASE END.

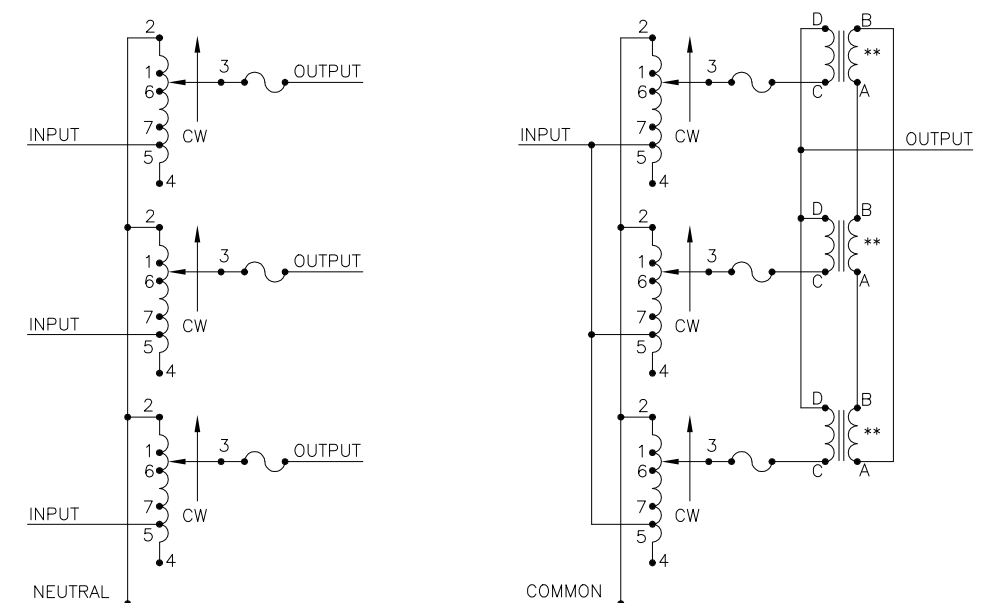

SCHEMATIC THREE PHASE WYE
 FUSES RECOMMENDED BUT NOT SUPPLIED

SCHEMATIC SINGLE PHASE PARALLEL
 FUSES RECOMMENDED BUT NOT SUPPLIED

SPECIFICATIONS										
WIRING	INPUT		OUTPUT				SHAFT ROTATION TO INCREASE VOLTAGE	TERMINAL CONNECTIONS +		
	VOLTS	HERTZ	VOLTS	CONSTANT CURRENT LOAD	CONSTANT IMPEDANCE LOAD	FOR INCREASING VOLTAGE AS VIEWED FROM BASE END ■				
				MAX. AMPS	MAX. KVA	MAX. AMPS	MAX. KVA	INPUT	JUMPER	OUTPUT
SINGLE PHASE PARALLEL **	240	50/60	0-240	30	7.20	39	9.30	CW	2-2-2, 4-4-4	4-D
			0-280	30	8.40	—	—	CCW	2-2-2, 4-4-4	2-D
	120	50/60	0-280	30#	3.60 §	—	—	CW	1-1-1, 4-4-4	4-D
			0-280	30#	3.60 §	—	—	CCW	7-7-7, 4-4-4	2-D
THREE PHASE WYE ∇	480	50/60	0-480	10	8.30	13	10.81	CW	2-2-2	4-4-4 3-3-3
			0-560	10	9.70	—	—	CCW	4-4-4	2-2-2 3-3-3
	240	60	0-560	10	9.70	—	—	CW	1-1-1	4-4-4 3-3-3
			0-560	10#	4.20 §	—	—	CCW	5-5-5	2-2-2 3-3-3

UNLESS OTHERWISE SPECIFIED, TOLERANCE IS * DECIMALS ** .0005 HOLES .01 ANGLES 1° DRAFT 1-1/2° UNITS IN [mm]

TITLE: SPEC. CONTROL DRAWING
 MOTORIZED VARIABLE XFMR.
 TYPE: M2520-3

MATERIAL: ALL DIMENSIONS APPLY AFTER PLATING

DRAWN BY: TIM RAU DATE: 8/6/97 FIRST USED ON: DO NOT SCALE DWG. CUSTOMER APPROVAL: DATE:

CHECKER: DATE: WEIGHT APPROX. 78 LBS. CODE IDENT. NO. 83008 DWG. NO. 031-5665

ENGINEER: DATE: SCALE .5=1 SHEET 1 OF 1

STACO ENERGY PRODUCTS CO. A COMPONENTS CORPORATION OF AMERICA COMPANY DAYTON, OHIO U.S.A.